



Professional LED Light Manufacturer  
Since 2008

[www.wilgex-led.com](http://www.wilgex-led.com)

(86) 769-28820681

[info@wilgex-led.com](mailto:info@wilgex-led.com)

# T25mm

**LED NEON FLEX**  
**SILICONE DYNAMIC PIXEL**  
**RGB COLOR**  
**24V**

SKU:WJ-SNF-T25-D-RGB-24V

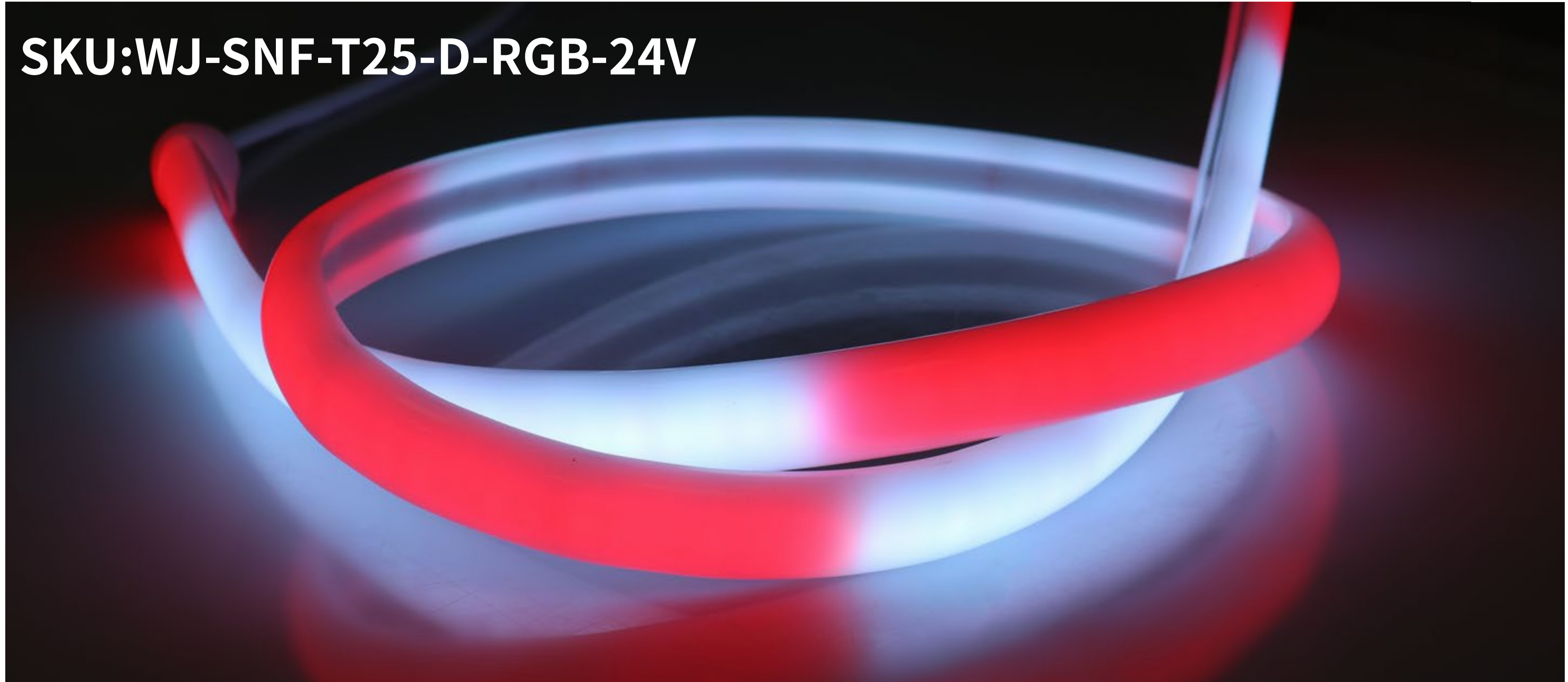

## Structural Drawing & Bending Direction

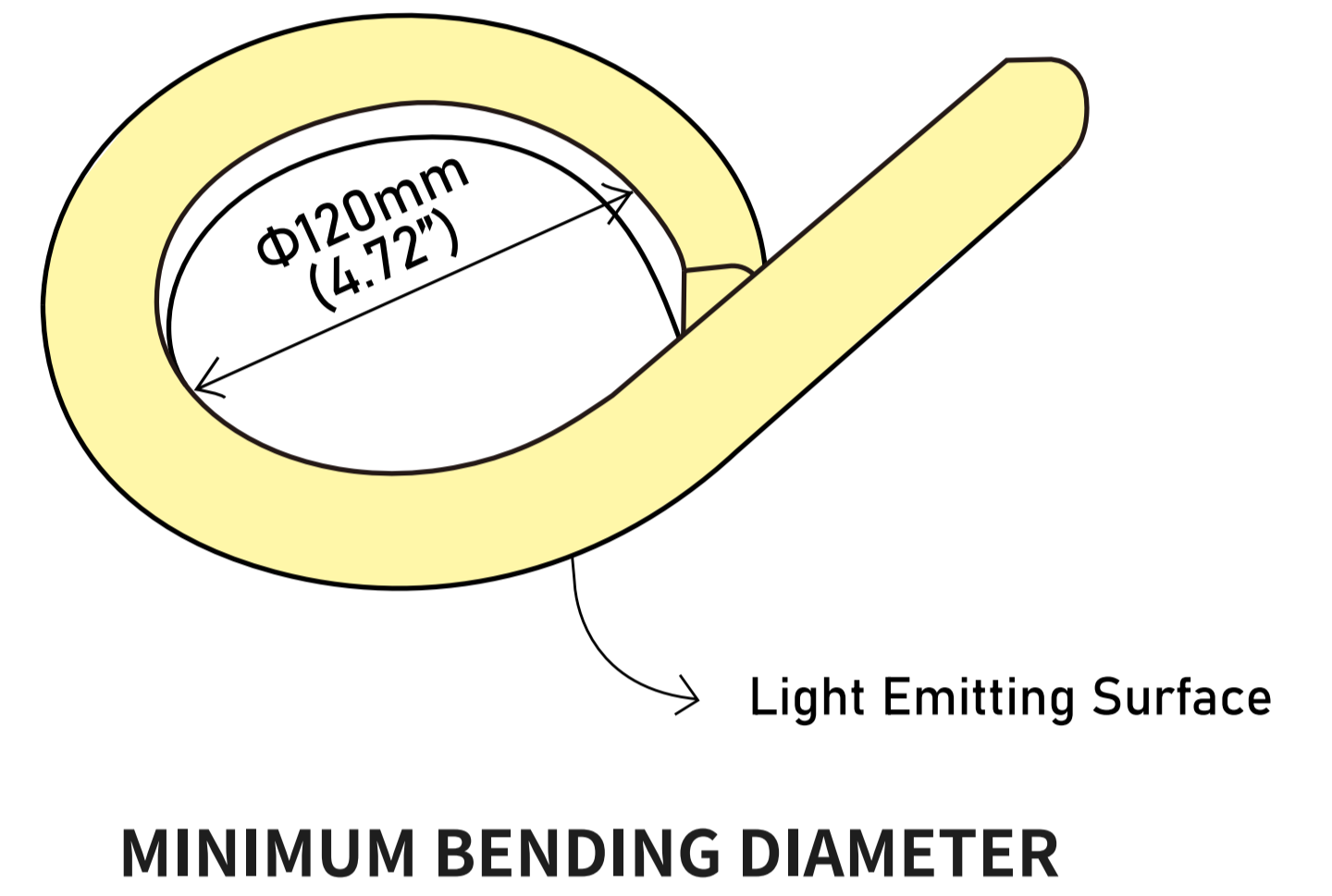
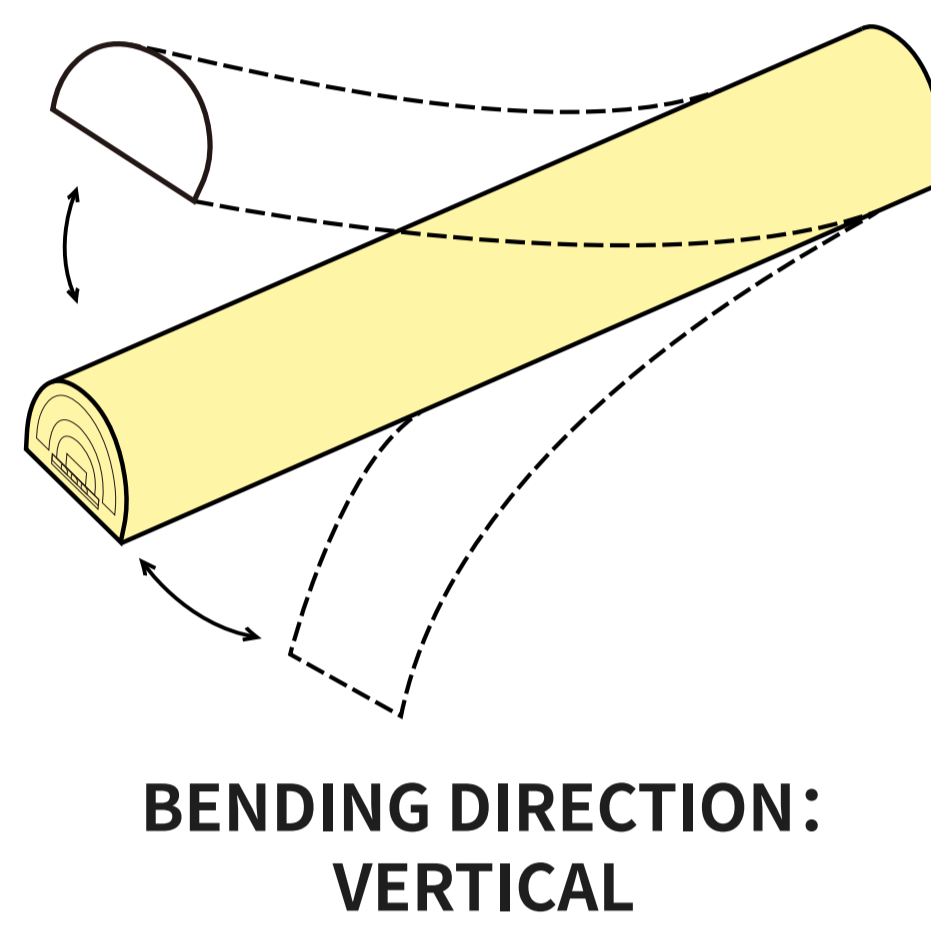
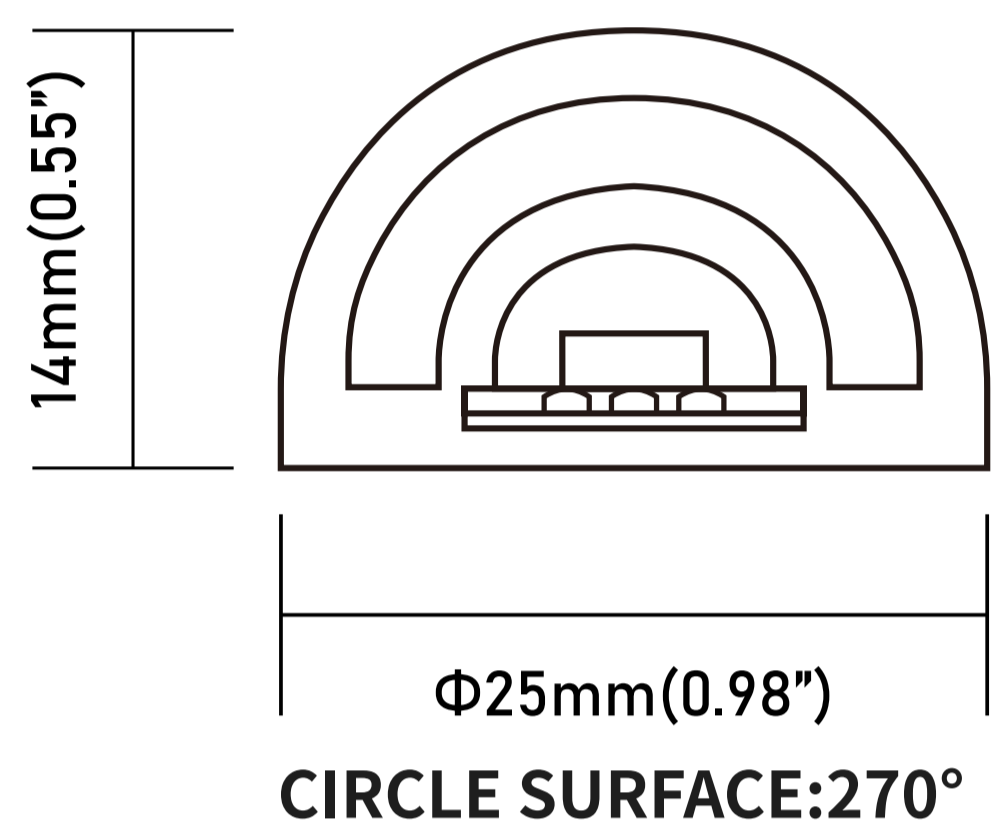

## Certifications



## Technical Data

SPI-RGB

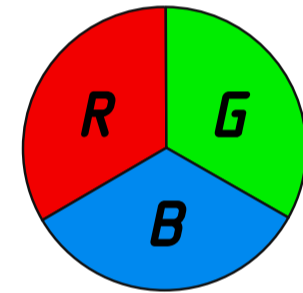

<b>Color Temp</b>	Red: 625.9nm Green: 525.8nm Blue: 470.1nm White: 6500K(Color mixing)	<b>Watts/m( 24V Flat)</b>	Red: 7.44 W Green: 7.55 W Blue: 7.53 W White: 19.20 W(Color mixing)
<b>Lumen/m ( 24V Flat)</b>	Red: 88.21 lm Green: 198.06 lm Blue: 34.81 lm White: 325.13 lm(Color mixing)	<b>Unit Cut(24V)</b>	12.5cm
<b>LED Quantity(m)</b>	112 LEDs + 16 ICs IC code: SM16703P (compatible with all ICs and controllers in the WS2811, 1804, and 1809 series)	<b>Max Loading(24V)</b>	5m

## Optical Parameter Chart for Integrating Sphere Testing

Chroma Parameters  
Chro.Coor.: x=0.2386 y=0.2497 u=0.1729 v=0.2715 uv=0.0089  
CCT: Tc=44704K Dominant Wave.: 480.1nm Purity: 39.7%  
Flux Ratio: R=20.9%,G=67.2%,B=11.9% Peak Wave.: 464.5nm Half Width: 20.8nm

Bending Index: Ra= 46.1  
R1 =34.6 R2 =52.5 R3 =67.0 R4 =54.2 R5 =56.2 R6 =54.0 R7 =50.8  
R8 =-0.3 R9 =-224.9R10=-10.3 R11=55.4 R12=54.8 R13=33.0 R14=77.7  
R15=10.6

Photo Parameters  
Flux: 487.391lm Effi.: 25.11lm/W Radiant: 2153.9mW Iv: 0.0mcd

Ele. Parameters  
Voltage:U=24.000V Current:I=0.8060A Power Factor:PF=1.000  
Power:P=19.35W

## Reliability test

TEST CATEGORY	TEST ITEMS	STANDARD/VALUE
Optical Test	Spectrum Analysis	IES LM 79(CCT, lumen, CRI, SDCM, XY, wavelength)
	Photometric Distribution	IES LM 79(lumen intensity distribution & Lux diagram)
	Lumen Maintenance & Lifetime	IES LM84 & IES TM 28
Temperature Test	Nomal Temperature Test -25°C	UL 1598 & UL2388 & IEC60598-1 & IEC60598-2-21
	Abnormal Operation Test -70°C	UL 1598 & UL2388 & IEC60598-1 & IEC60598-2-21
Physics Test	Bending Test	Manufacturer-defined, 1000 cycles
	Swing Test	UL2388, >750 cycles
	Tensile Test	Manufacturer-defined, >the weight of light in max. running length by double ends feed
	Twist Test	Manufacturer-defined, 200 cycles
	IK08	IEC62262
Weathering Test	Ball Impact	UL 1598 & UL2388 & IEC60598-1 & IEC60598-2-21
	Swimming Pool Water Immersion Test	GB9667, PH6.8-7.6, free chlorine 0.3-0.6mg/L
	Sea Water Immersion Test	IEC 60598-1, Salinity 4%
	Salt Spray Test	IEC68-2-11
Environment Test	Outdoor Exposure	Manufacturer-defined
	Flame Resistant Test	UL94
	UV Exposure Test	ASTMG154, UVA@340nm
	IPX5 IPX6 IPX7 IPX8	IEC60529
	Temperature Shock Test	Manufacturer-defined, -40°C-60°C(typical temperature range)
Constant Temperature Test	Manufacturer-defined, 70°C(typical temperature range)	

Wilgex specializes in engineering LED flexible neon lights and offers both standard and customized services. If you have specific requirements, please contact our sales department.

**Four-star quality assurance**

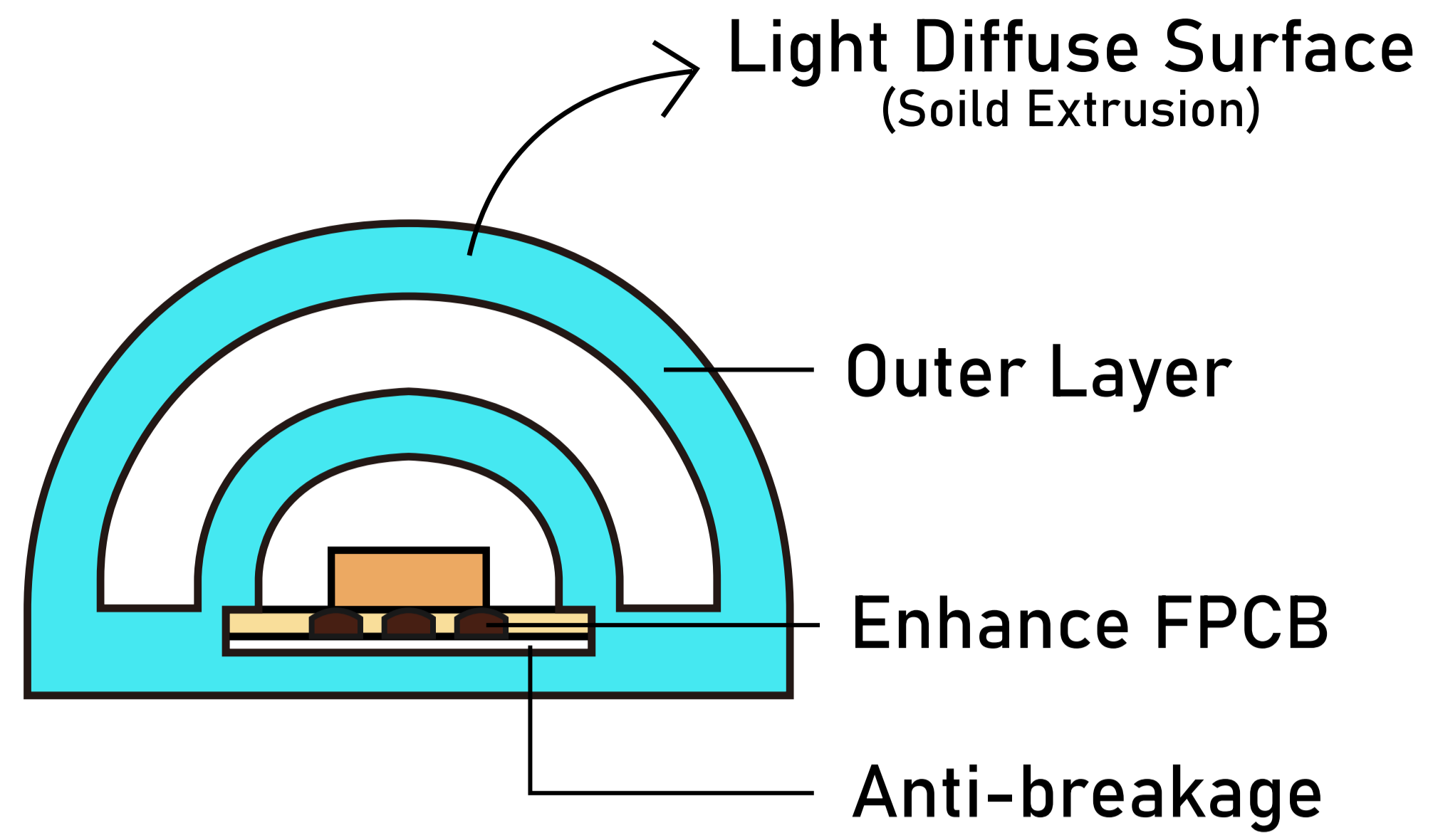

**Unique Design**



★ Enhance thickness FPC design principle

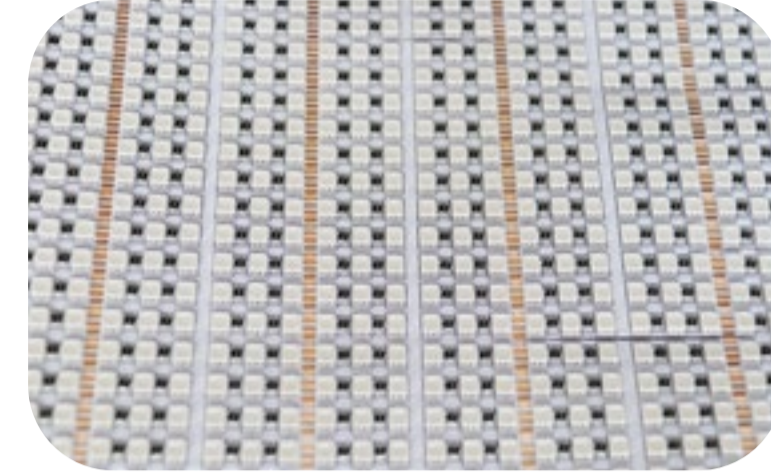

★ LED anti-death design

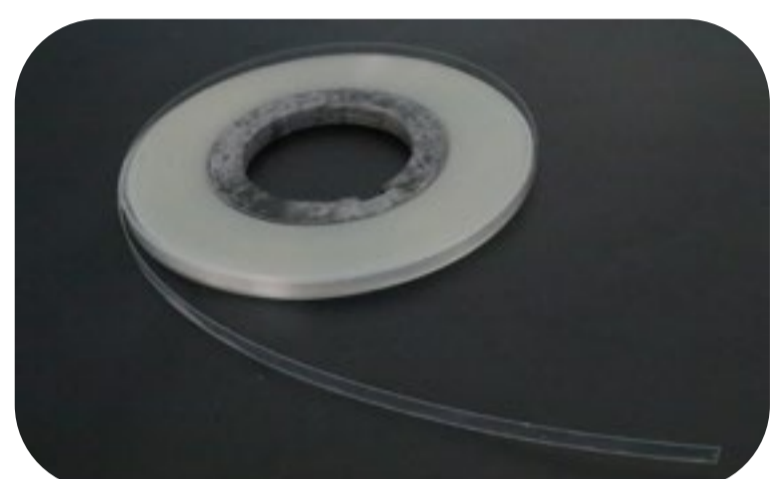

★ Add a break protection layer



★ Solid extrusion design for exterior

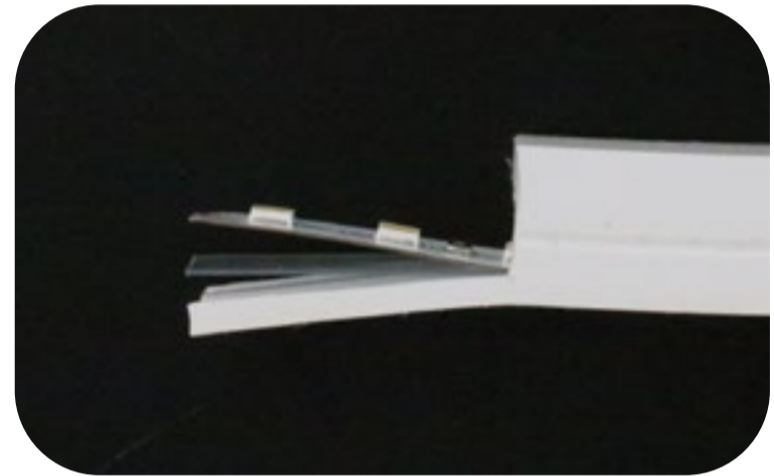

**Features:**

1. Size: The size of this LED Neon Flex is T25mm (half round shape).
2. High-density LED chips: The strips have a high density of LED chips, resulting in a brighter and more uniform light output
3. Flexible and bendable: Can be bent into various shapes and designs
4. Energy-efficient: Uses less power compared to traditional neon lights
5. Long lifespan: Can last up to 50,000 hours
6. Low heat emission: Does not emit as much heat as traditional neon lights
7. Wide color options: Available in a wide range of colors
8. Easy to install: Can be cut and connected to fit any desired length and shape
9. Durable and weather-resistant: Can withstand various weather conditions
10. Safe to use: Low voltage and does not contain hazardous materials like mercury
11. Cost-effective: Offers a cost-effective alternative to traditional neon lights.

**Wide Color Options**



Dynamic Pixel RGB

**Recommended Usage Scenarios :**

1. Indoor and outdoor architectural lighting decoration
2. Landscape lighting
3. Advertising signage lighting
4. Stage and theater lighting
5. Car and motorcycle lighting
6. Holiday and event lighting decoration
7. Cove lighting
8. Edge-lit lighting
9. Retail and display lighting
10. Restaurant and bar lighting

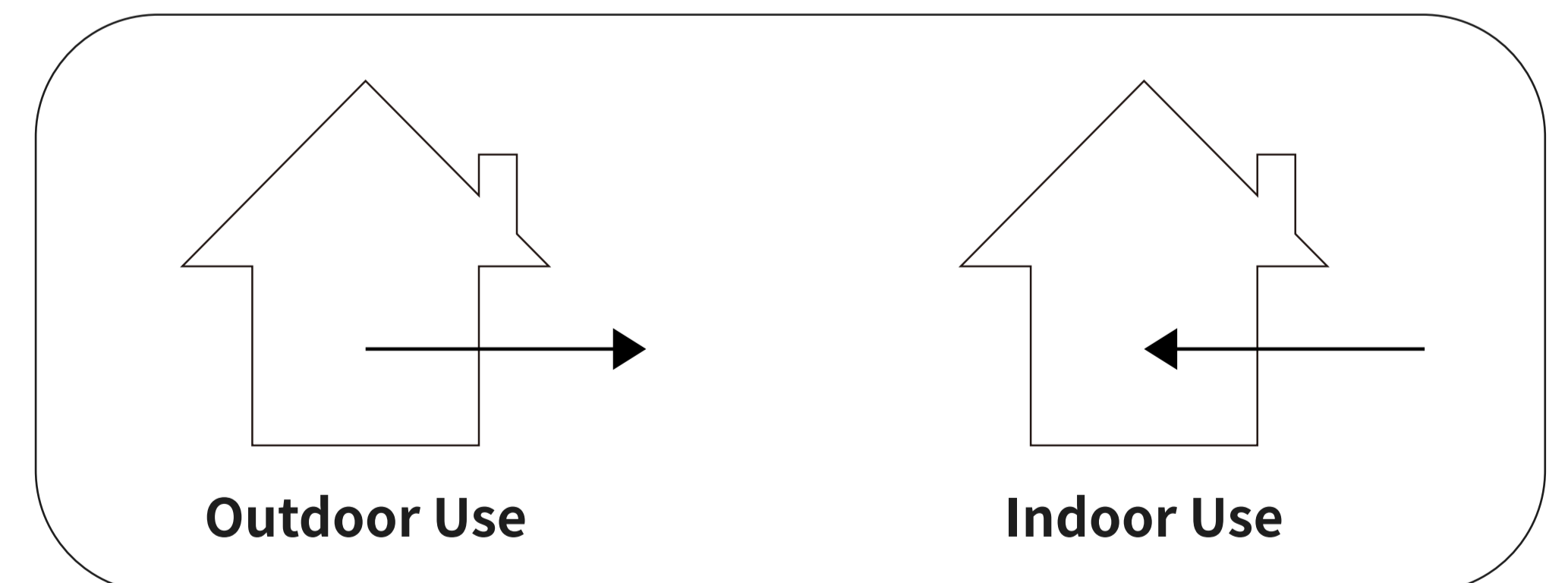

Please note that these are only recommended usage scenarios and it is important to consult the product specifications and guidelines before using flexible LED neon light strips in any application.



**Package**



Packing Method : Blister + White box  
 Quantity / Box : 5 meters / reel  
 Gross Weight : 1.695 Kg (3.74LB)  
 Size of outer box : 52x 52x 7 cm  
 CBM : 0.019m<sup>3</sup> / box

**Mini Cutting Length & Connection Length**

**• Voltage ( 24V)**

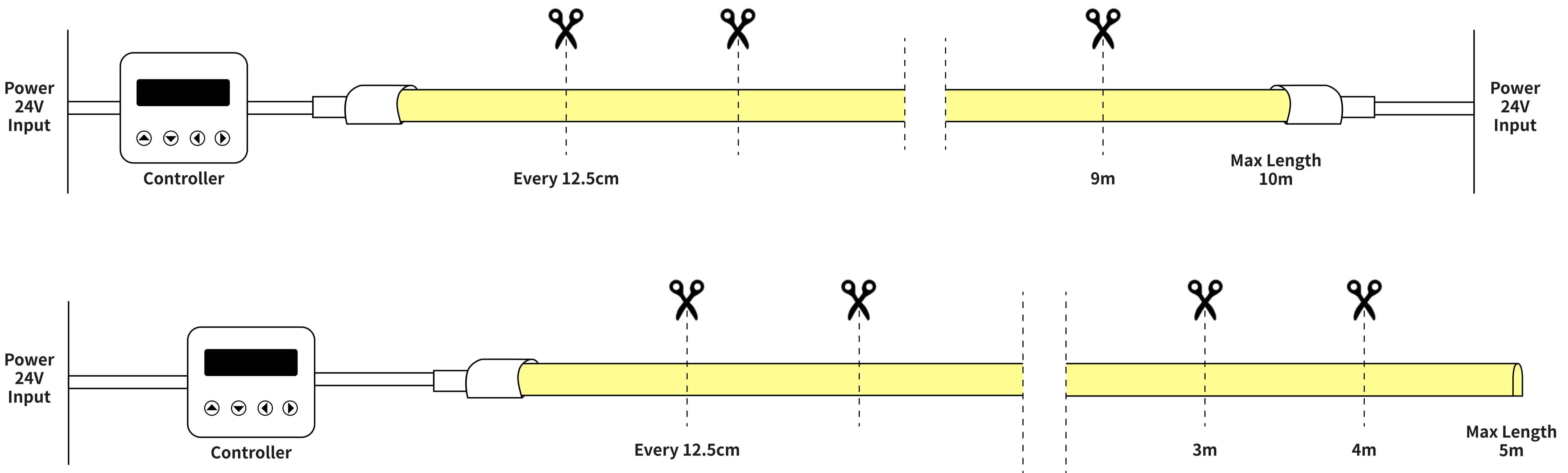

**Controller Selection**



**HC100**  
Updated version SPI magic color controller



**LT-200**  
LED Digital Controller



**SP108E LED WIFI Controller**

**IP65 (DIY Connector)**

**• Voltage ( 24V)**



**FRONT CONNECTION**



**END CAP**