



Professional LED Light Manufacturer
Since 2008

www.wilgex-led.com

(86) 769-28820681

info@wilgex-led.com

LED NEON FLEX

Dia 22mm
ROUND

RGBW COLOR
24V

SKU:WJ-SNF-D22-RGBW-24V



Structural Drawing & Bending Direction

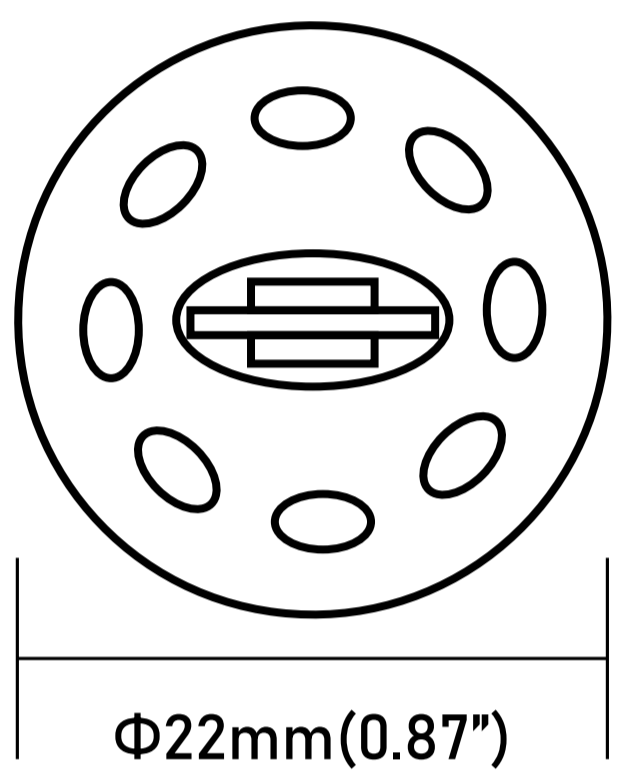

CIRCLE / LIGHT BEAM ANGLE:360°

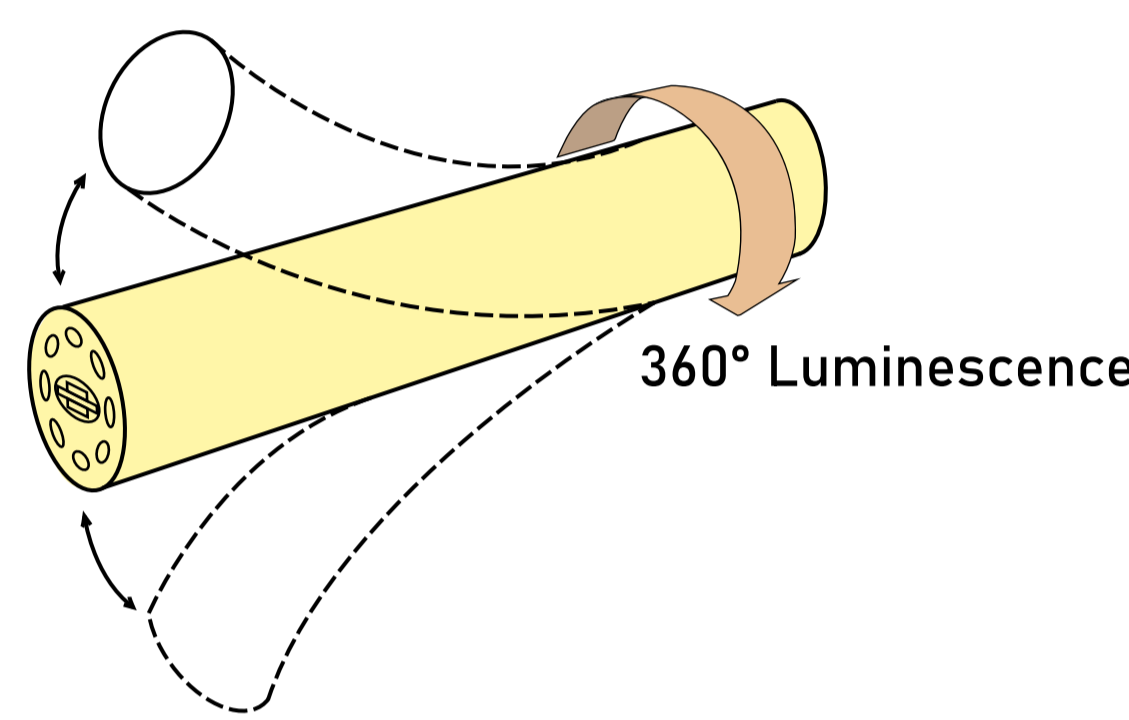

BENDING DIRECTION:
VERTICAL

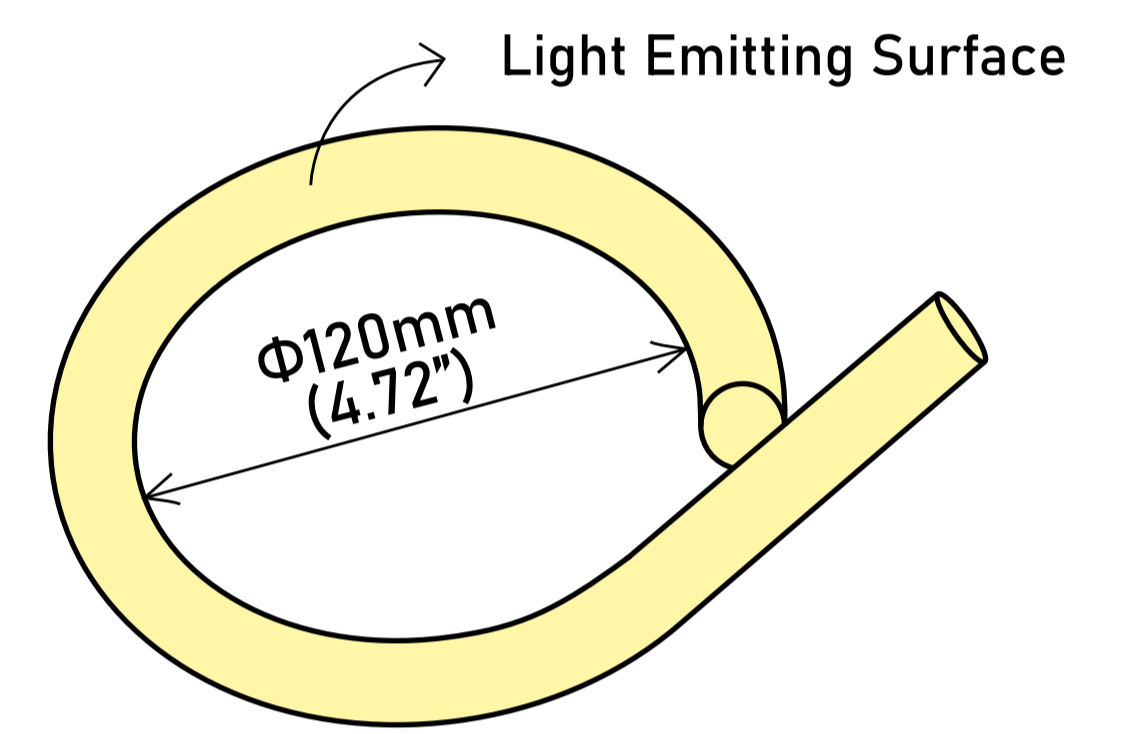

MINIMUM BENDING DIAMETER

Certifications



Technical Data

PWM-RGBW

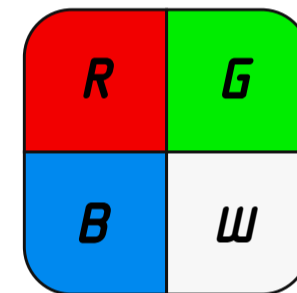

Color Temp	Red:623.4nm Green:525.5nm Blue:470.1nm White:2905K RGBW:5948K(Color mixing)	Watts/m(24V Flat)	Red:10.63 W Green:10.66 W Blue:10.06 W White:11.09 W RGBW:37.44 W (Color mixing)
Lumen/m (24V Flat)	Red:286.43 lm Green:584.45 lm Blue:584.45 lm White:770.53 lm RGBW:1389.40lm(Color mixing)	Unit Cut(24V)	6.25cm
LED Quantity(m)	2x112 LEDs	Max Loading(24V)	5m

Optical Parameter Chart for Integrating Sphere Testing

Chroma Parameters
Chro.Coor.: x=0.3230 y=0.3327 u=0.2036 v=0.3145 duv=0.0000
CCT: Tc= 5954K Dominant Wave.: 492.0nm Purity: 3.5%
Flux Ratio: R=21.7%,G=72.2%,B=6.1% Peak Wave.: 637.6nm Half Width: 24.7nm

Bending Index: Ra= 65.5
R1 =57.2 R2 =75.0 R3 =88.3 R4 =63.2 R5 =62.9 R6 =66.2 R7 =72.9
R8 =38.8 R9 =-62.7 R10=43.5 R11=55.8 R12=61.7 R13=59.7 R14=90.9
R15=50.0

Photo Parameters
Flux: 1388.131m Effi.: 36.91m/W Radiant: 4844.1mW Iv: 0.0mcd

Ele. Parameters
Voltage:U=24.000V Current:I=1.5650A
Power:P=37.61W Power Factor:PF=1.000

Reliability test

TEST CATEGORY	TEST ITEMS	STANDARD/VALUE
Optical Test	Spectrum Analysis	IES LM 79(CCT, lumen, CRI, SDCM, XY, wavelength)
	Photometric Distribution	IES LM 79(lumen intensity distribution & Lux diagram)
Temperature Test	Lumen Maintenance & Lifetime	IES LM84 & IES TM 28
	Nomal Temperature Test -25°C	UL 1598 & UL2388 & IEC60598-1 & IEC60598-2-21
	Abnormal Operation Test -70°C	UL 1598 & UL2388 & IEC60598-1 & IEC60598-2-21
Physics Test	Bending Test	Manufacturer-defined, 1000 cycles
	Swing Test	UL2388, >750 cycles
	Tensile Test	Manufacturer-defined, >the weight of light in max. running length by double ends feed
	Twist Test	Manufacturer-defined, 200 cycles
	IK08	IEC62262
Weathering Test	Ball Impact	UL 1598 & UL2388 & IEC60598-1 & IEC60598-2-21
	Swimming Pool Water Immersion Test	GB9667, PH6.8-7.6, free chlorine 0.3-0.6mg/L
	Sea Water Immersion Test	IEC 60598-1, Salinity 4%
	Salt Spray Test	IEC68-2-11
Environment Test	Outdoor Exposure	Manufacturer-defined
	Flame Resistant Test	UL94
	UV Exposure Test	ASTMG154, UVA@340nm
	IPX5 IPX6 IPX7 IPX8	IEC60529
	Temperature Shock Test	Manufacturer-defined, -40°C-60°C(typical temperature range)
Constant Temperature Test	Manufacturer-defined, 70°C(typical temperature range)	

Wilgex specializes in engineering LED flexible neon lights and offers both standard and customized services. If you have specific requirements, please contact our sales department.

Four-star quality assurance

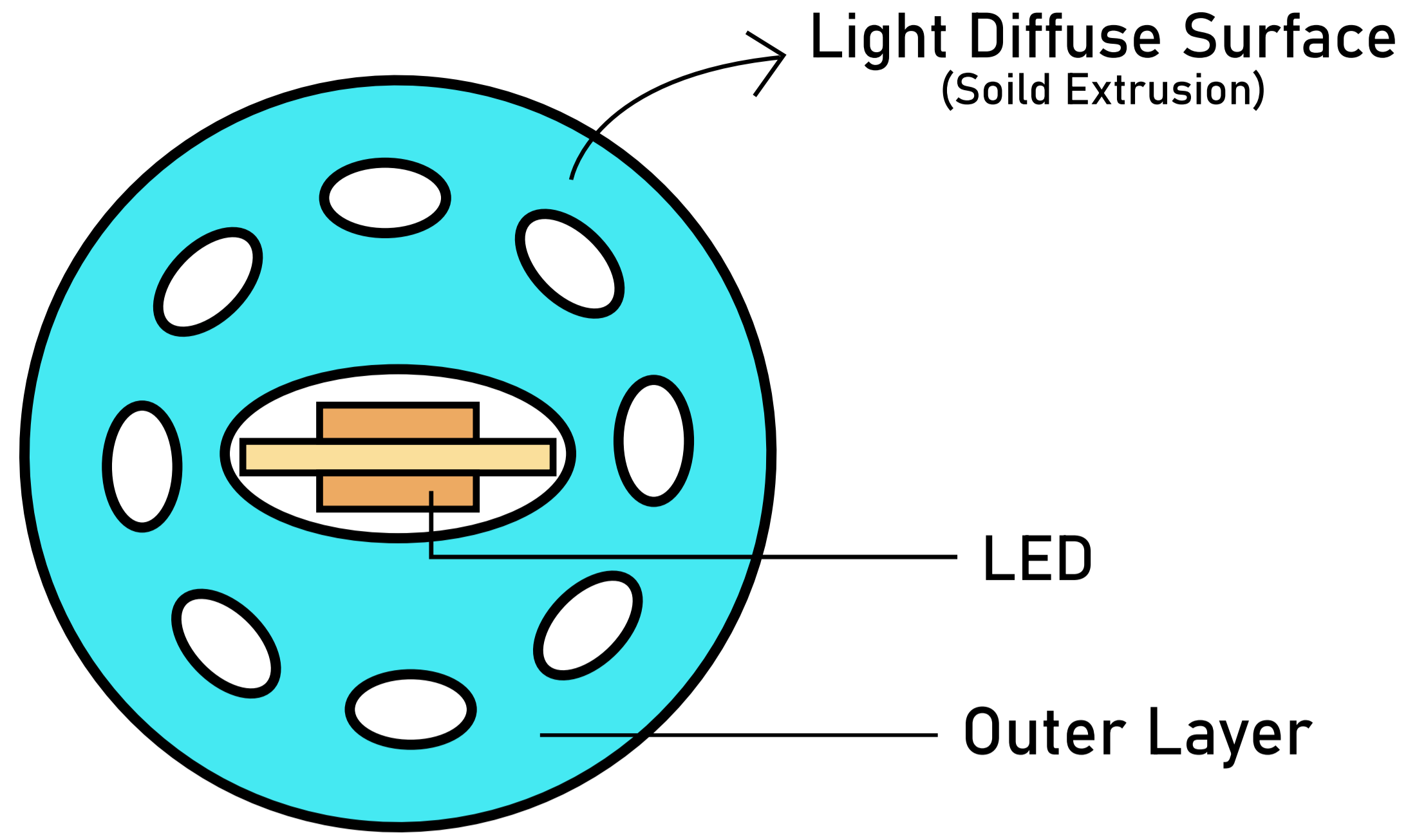
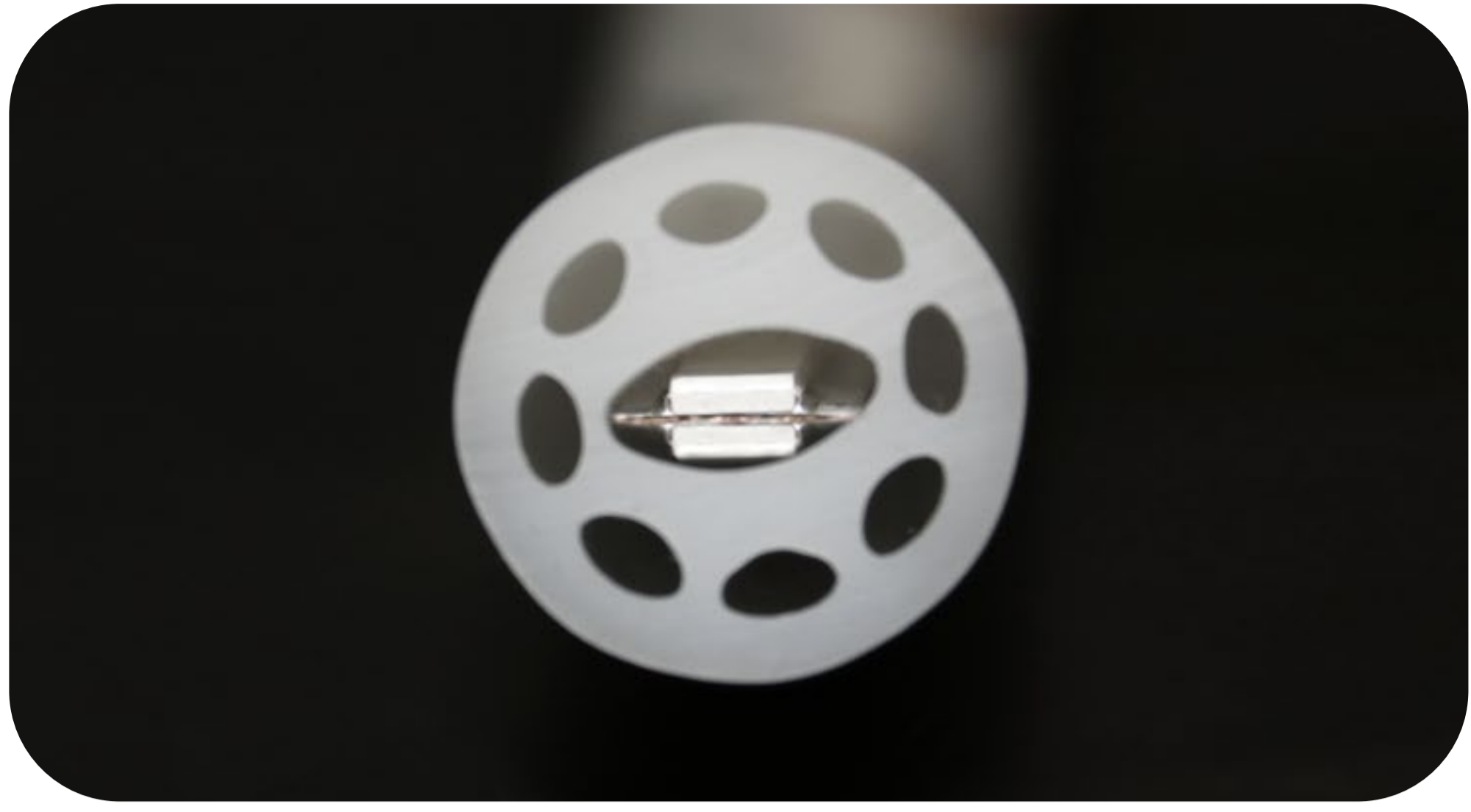

Unique Design

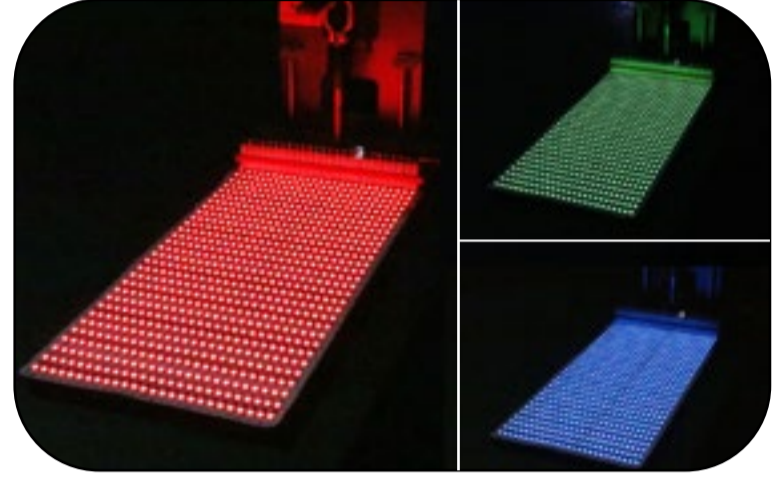

★ Enhance thickness FPC design principle



★ LED anti-death design

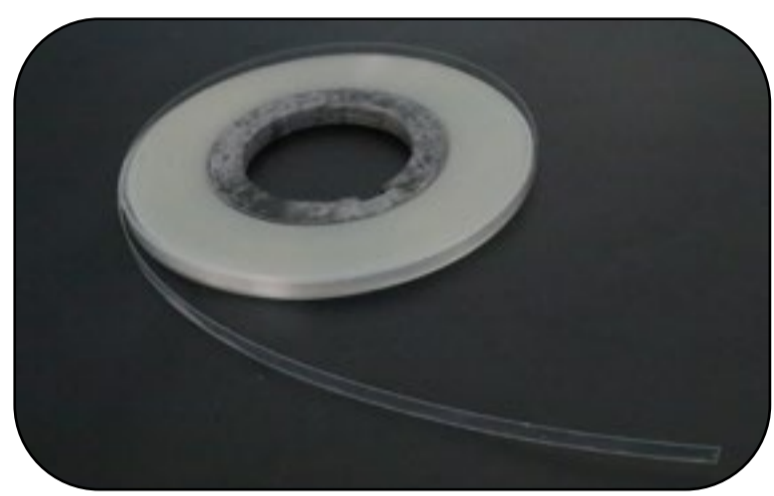

★ Add a break protection layer



★ Solid extrusion design for exterior

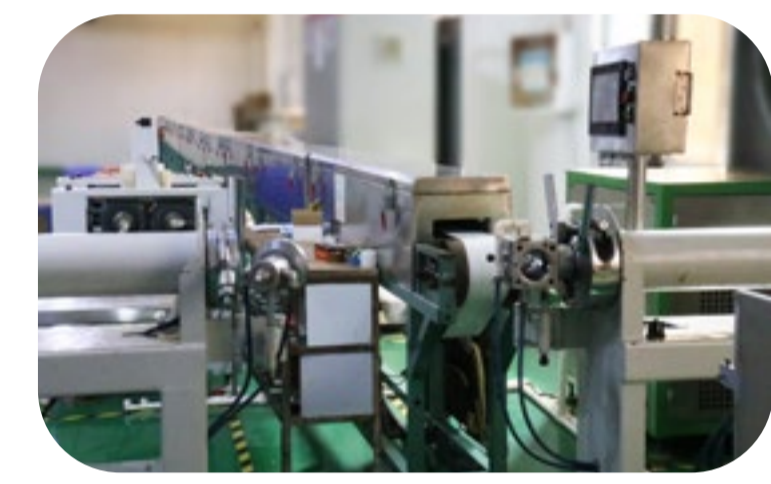
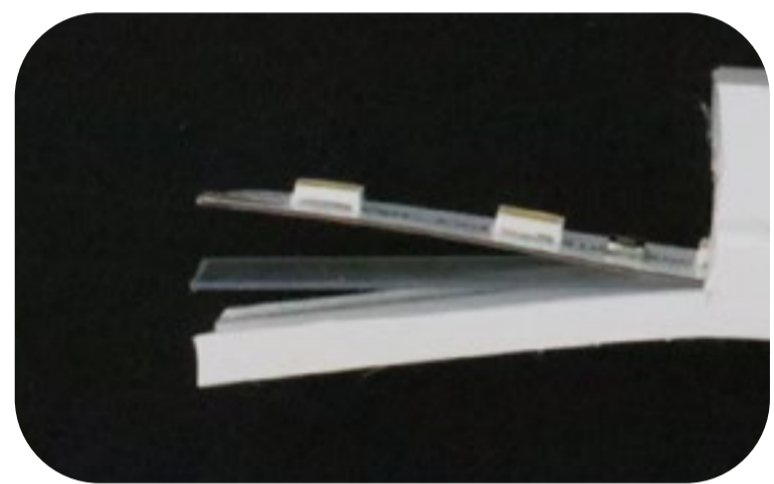

Features:

1. Size: The LED chips have a size of $\Phi 22\text{mm}$ in round shape.
2. Color: The RGBW LED flexible neon light strip can display a wide range of colors, including red, green, blue, and white. This allows for a high degree of customization and creativity in lighting design.
3. Flexibility: The LED strip is flexible and can be bent and twisted to fit any shape or space. This makes it ideal for installations in tight spaces or for creating unique lighting designs.
4. Durability: The LED strip is made of durable materials that are resistant to water, dust, and other environmental factors. This makes it suitable for both indoor and outdoor applications.
5. Energy Efficiency: The LED strip consumes very little energy compared to traditional lighting sources, making it an eco-friendly and cost-effective lighting solution.
6. Easy to Install: The LED strip is easy to install and can be cut to fit any length. It can be attached to a variety of surfaces using mounting brackets or adhesive tape.
7. Overall, the RGBW LED flexible neon light strip is a versatile, durable, and energy-efficient lighting solution that offers a wide range of design possibilities.

Wide Color Options

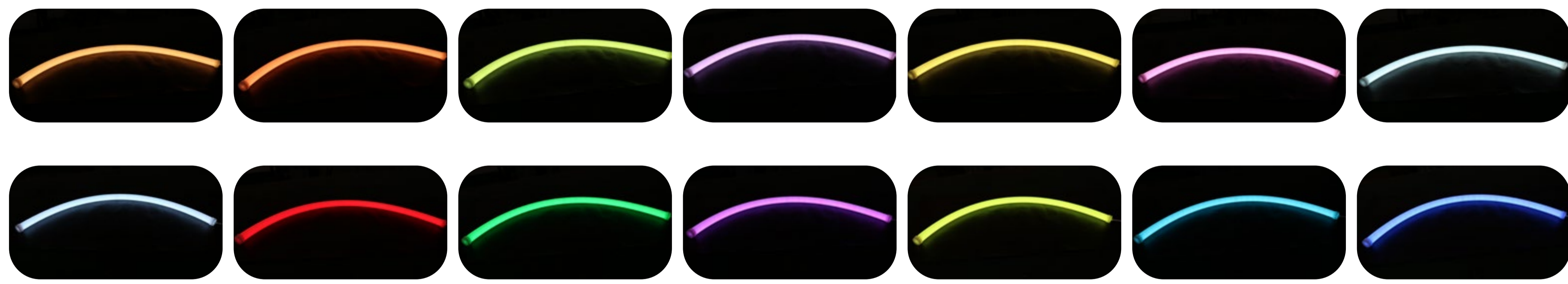

RGBW Color Mixing - Color changing, Fading, Chasing effect

Recommended Usage Scenarios :

1. Indoor and outdoor architectural lighting decoration
2. Landscape lighting
3. Advertising signage lighting
4. Stage and theater lighting
5. Car and motorcycle lighting
6. Holiday and event lighting decoration
7. Cove lighting
8. Edge-lit lighting
9. Retail and display lighting
10. Restaurant and bar lighting

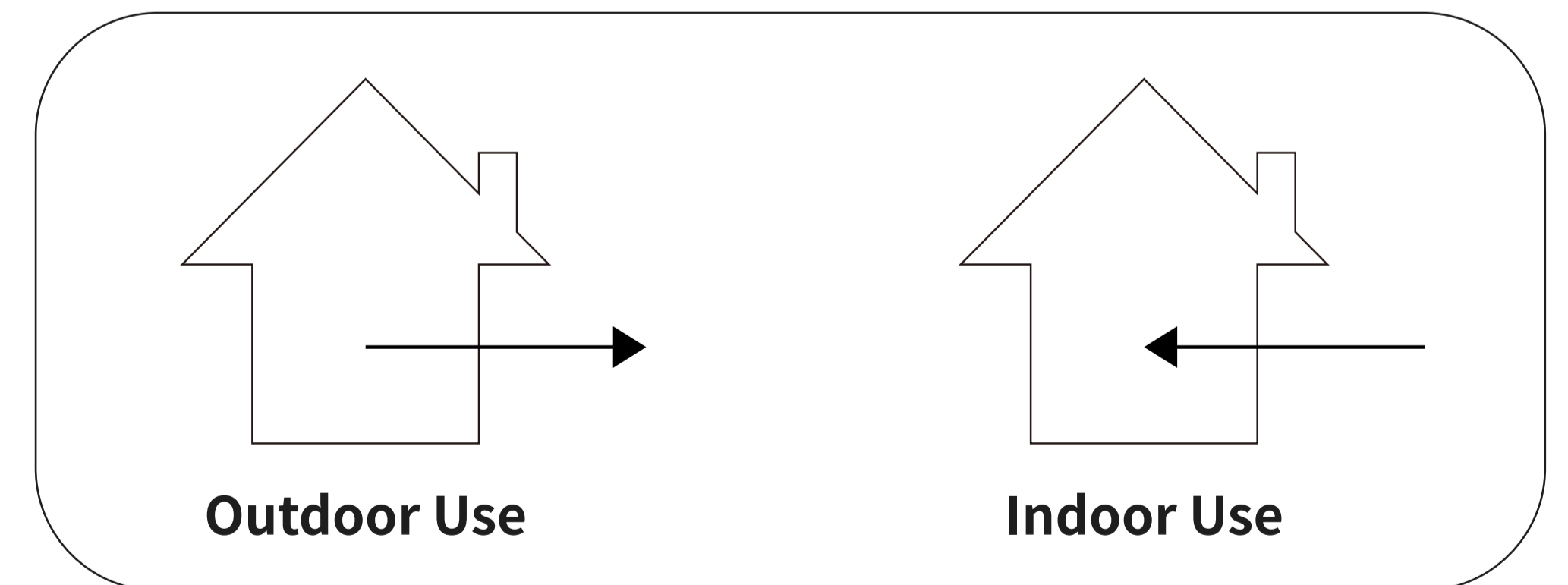

Please note that these are only recommended usage scenarios and it is important to consult the product specifications and guidelines before using flexible LED neon light strips in any application.



Package



Packing Method : Blister + White box
 Quantity / Box : 5 meters / reel
 Gross Weight : 2.25 Kg (4.96LB)
 Size of outer box : 52x 52x 7 cm
 CBM : 0.019m³ / box

Mini Cutting Length & Connection Length

• Voltage (24V)

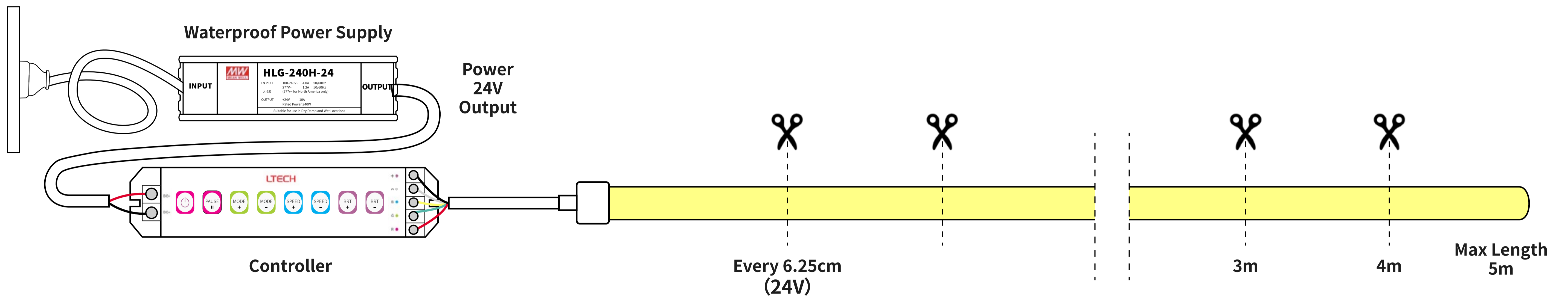

IP65 (DIY Connector)

• Voltage (24V)

• Part Details



FRONT CONNECTION



END CAP

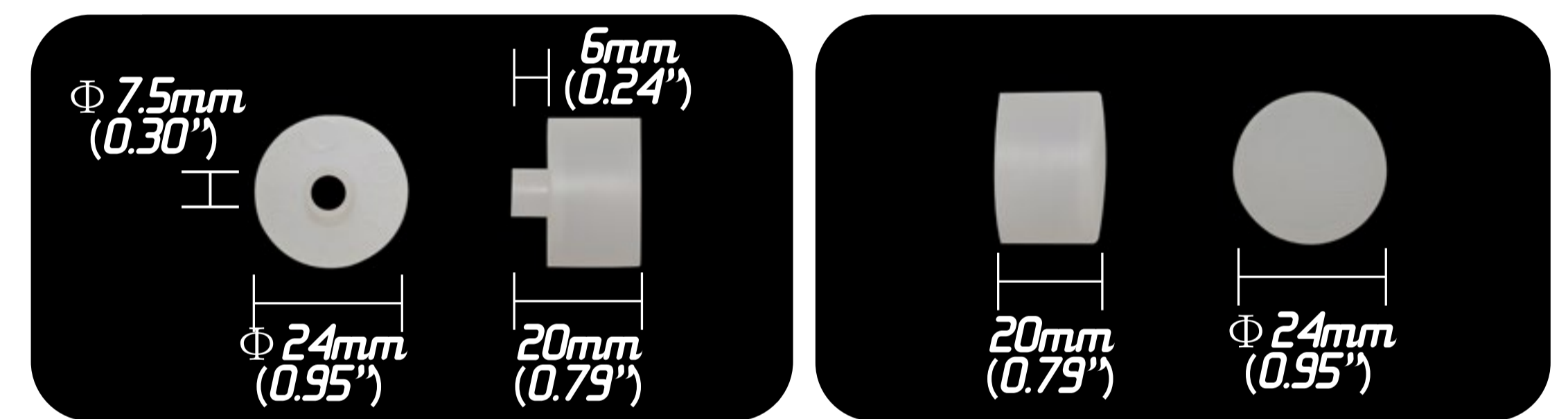

SILICONE POWER WIRE (5 CORDS)

Mounting Plastic Transparent Channel

